

GALVASHIELD® N ANODE PROPERTIES

MINIMUM WEIGHT OF ZINC CORE	60 g
OVERALL LENGTH OF TIE WIRES	600 mm
NOMINAL DIMENSIONS OF ANODE	125 mm x 25 mm x 25 mm
ANODE TYPE / CLASS	1A / P
ALKALI ACTIVATED CORROSION PREVENTION	

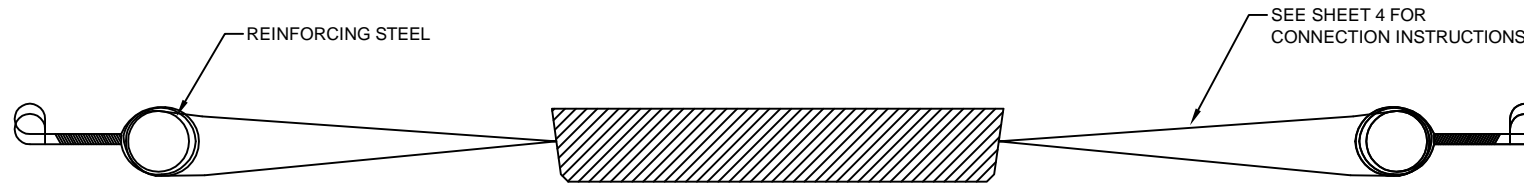

1. ENSURE ALL REINFORCING STEEL IS CLEAN AND UNDAMAGED AND SECURELY FASTENED WITH TIE WIRE TO PROVIDE GOOD ELECTRICAL CONTINUITY.
2. ATTACH GALVASHIELD® N ANODES TO CLEAN REINFORCING STEEL AT AN EVEN SPACING AS OUTLINED IN PROJECT SPECIFICATIONS (MAX 750mm OR 0.25m² STEEL SURFACE AREA PER ANODE).
3. GALVASHIELD® N ANODES ARE INSTALLED IN A GRID PATTERN WITHIN THE INTERIOR OF THE NEW CONCRETE CONSTRUCTION AREA.
4. TEST ELECTRICAL CONTINUITY OF THE REINFORCING STEEL BEFORE INSTALLATION AND REPAIR AS NECESSARY. TEST ELECTRICAL CONTINUITY OF ANODE CONNECTION TO REINFORCING STEEL AFTER INSTALLATION. A DC VOLTAGE MEASUREMENT OF 1mV CONFIRMS GOOD CONTINUITY.
5. POUR BACK CONCRETE WITH COMPATIBLE MATERIAL AS PER PROJECT SPECIFICATIONS. TAKE CARE NOT TO DAMAGE ANODES DURING PLACEMENT OF CONCRETE.



SECTION OF TYPICAL INSTALLATION

N.T.S.

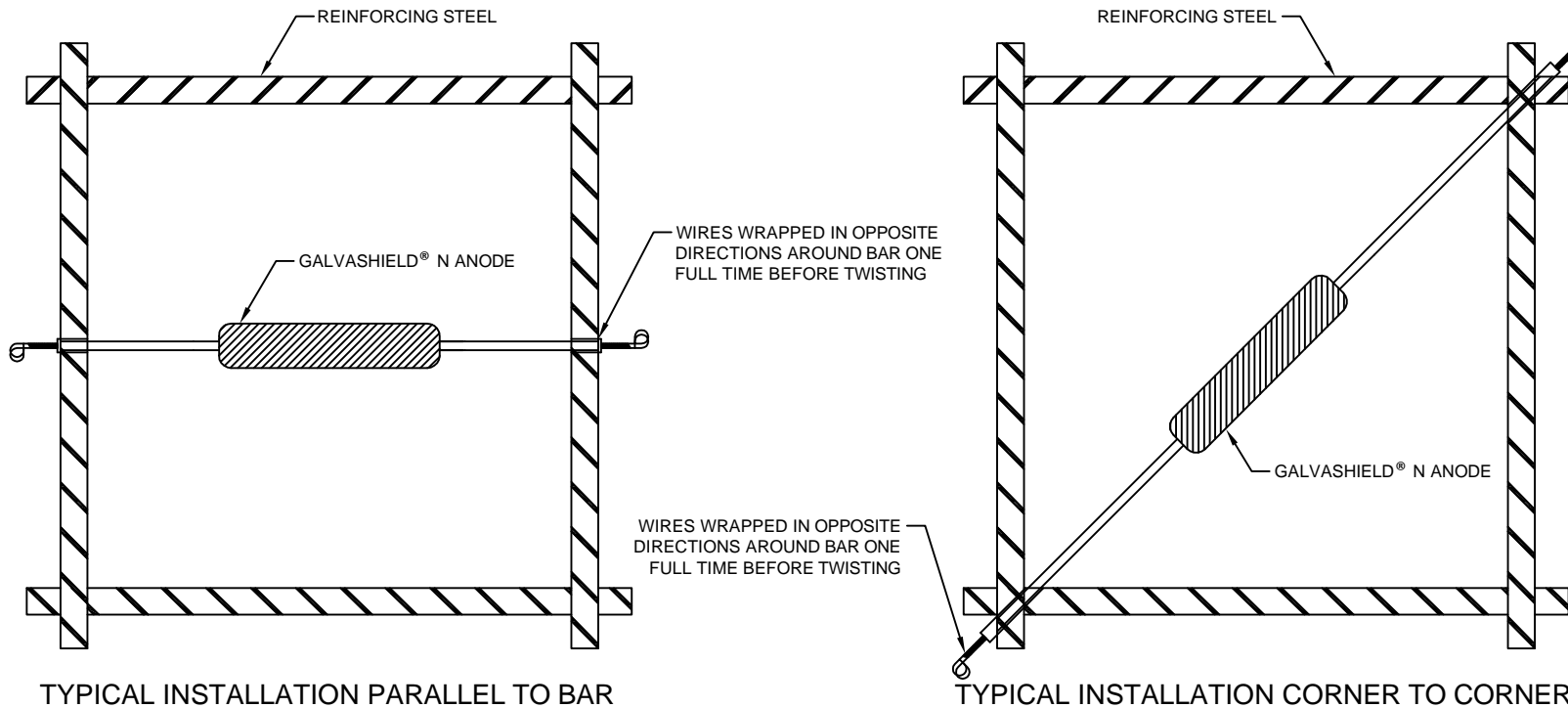

TYPICAL INSTALLATION PARALLEL TO BAR

N.T.S.

TYPICAL INSTALLATION CORNER TO CORNER

N.T.S.

**GALVASHIELD® N
EMBEDDED
GALVANIC ANODES**

**TYPICAL INSTALLATION
DETAILS**

BY: JWH DATE: Nov 20-2012

SHEET: 1 OF 4

N CONNECTION.DWG

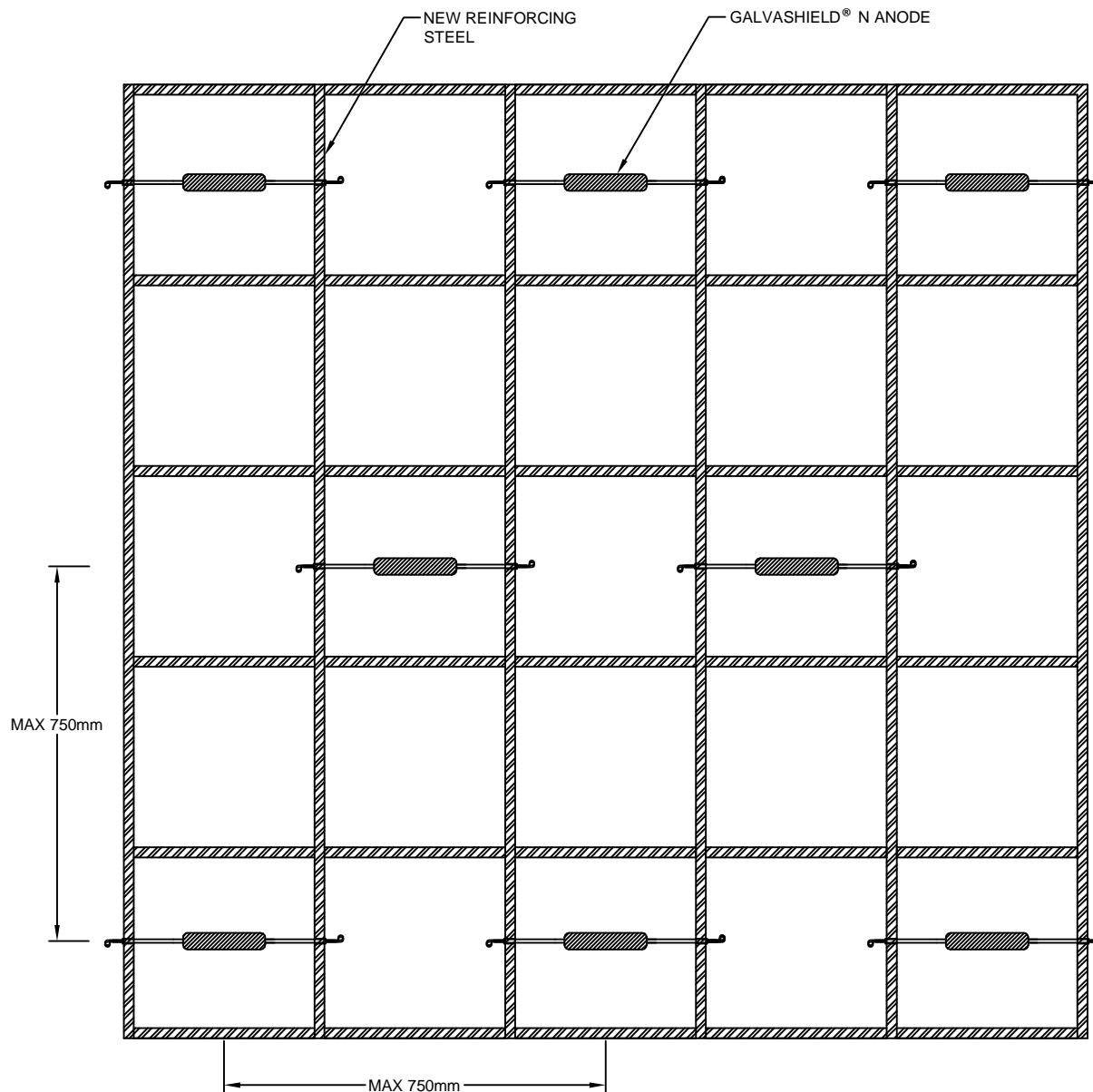

PLAN OF TYPICAL STAGGERED ANODE GRID LAYOUT FOR CONCRETE SLAB

N.T.S.

1. ENSURE ALL REINFORCING STEEL IS CLEAN AND UNDAMAGED AND SECURELY FASTENED WITH TIE WIRE TO PROVIDE GOOD ELECTRICAL CONTINUITY.

2. ATTACH GALVASHIELD® N ANODES TO CLEAN REINFORCING STEEL AT AN EVEN SPACING AS OUTLINED IN PROJECT SPECIFICATIONS (MAX 750mm).

3. GALVASHIELD® N ANODES ARE INSTALLED IN A GRID PATTERN WITHIN THE INTERIOR OF THE NEW CONCRETE CONSTRUCTION AREA.

4. TEST ELECTRICAL CONTINUITY OF THE REINFORCING STEEL BEFORE INSTALLATION AND REPAIR AS NECESSARY. TEST ELECTRICAL CONTINUITY OF ANODE CONNECTION TO REINFORCING STEEL AFTER INSTALLATION. A DC VOLTAGE MEASUREMENT OF 1mV CONFIRMS GOOD CONTINUITY.

5. POUR BACK CONCRETE WITH COMPATIBLE MATERIAL AS PER PROJECT SPECIFICATIONS. TAKE CARE NOT TO DAMAGE ANODES DURING PLACEMENT OF CONCRETE.

**GALVASHIELD® N
EMBEDDED
GALVANIC ANODES**

**ANODE GRID LAYOUT
FOR CONCRETE SLAB**

BY: JWH DATE: Nov 20-2012

SHEET: 2 OF 4

N CONNECTION.DWG

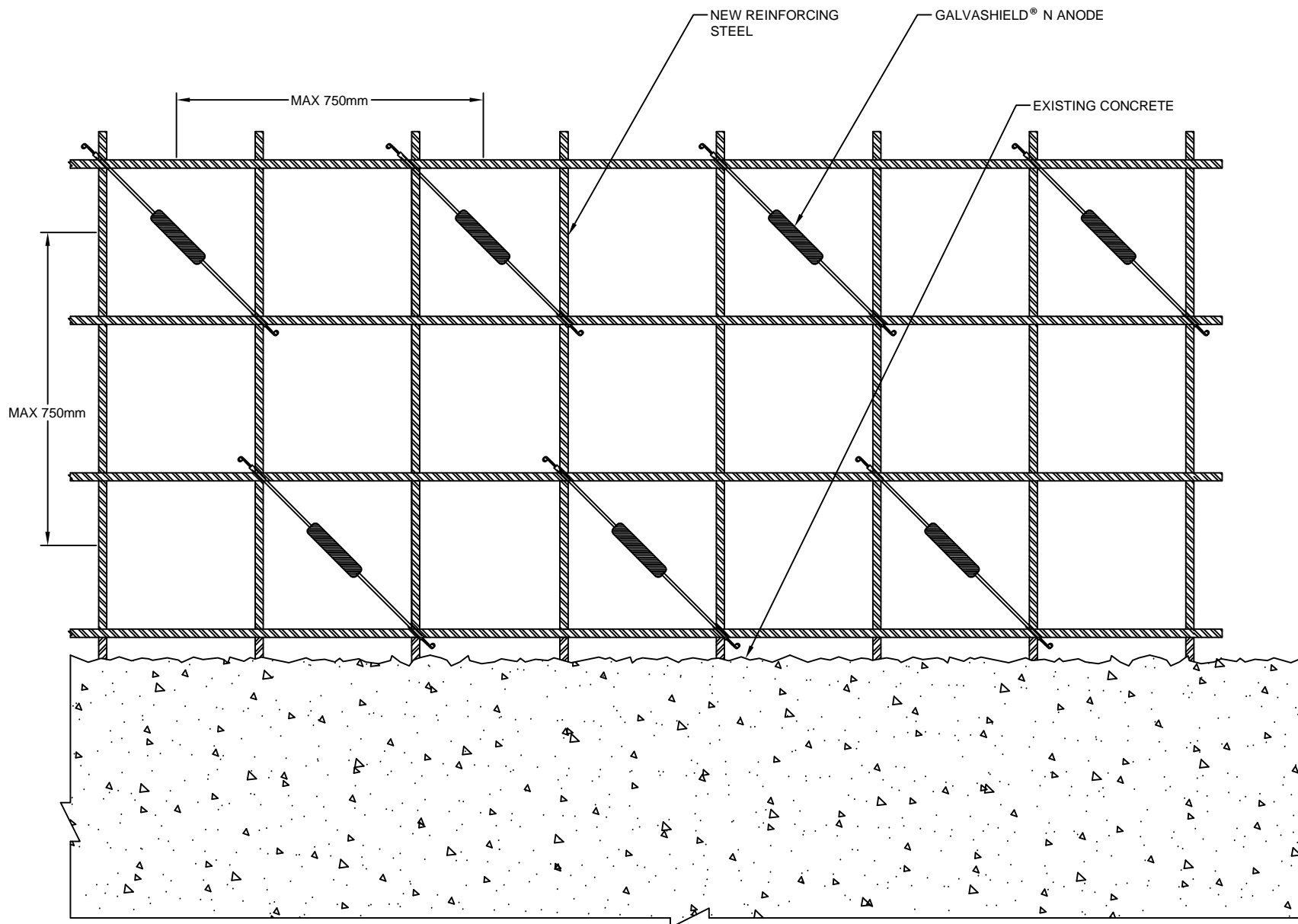

1. ENSURE ALL REINFORCING STEEL IS CLEAN AND UNDATED AND SECURELY FASTENED WITH TIE WIRE TO PROVIDE GOOD ELECTRICAL CONTINUITY.

2. ATTACH GALVASHIELD® N ANODES TO CLEAN REINFORCING STEEL AT AN EVEN SPACING AS OUTLINED IN PROJECT SPECIFICATIONS (MAX 750mm).

3. GALVASHIELD® N ANODES ARE INSTALLED IN A GRID PATTERN WITHIN THE INTERIOR OF THE NEW CONCRETE CONSTRUCTION AREA.

4. TEST ELECTRICAL CONTINUITY OF THE REINFORCING STEEL BEFORE INSTALLATION AND REPAIR AS NECESSARY. TEST ELECTRICAL CONTINUITY OF ANODE CONNECTION TO REINFORCING STEEL AFTER INSTALLATION. A DC VOLTAGE MEASUREMENT OF 1mV CONFIRMS GOOD CONTINUITY.

5. POUR BACK CONCRETE WITH COMPATIBLE MATERIAL AS PER PROJECT SPECIFICATIONS. TAKE CARE NOT TO DAMAGE ANODES DURING PLACEMENT OF CONCRETE.

**GALVASHIELD® N
EMBEDDED
GALVANIC ANODES**

**ANODE LAYOUT
FOR CONSTRUCTION
JOINT**

PLAN OF TYPICAL STAGGERED GRID LAYOUT FOR CONSTRUCTION JOINT

N.T.S.

BY: JWH DATE: Nov 20-2012

SHEET: 3 OF 4

N CONNECTION.DWG

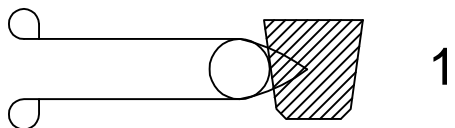

1

1: PLACE ANODE SNUGLY AGAINST FACE OF REBAR WITH ONE (1) WIRE ON EITHER SIDE OF REBAR

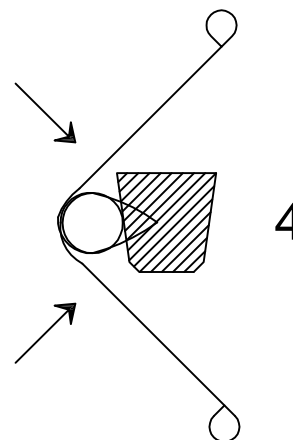

4

4 & 5: WRAP WIRES TIGHTLY ONCE AROUND REBAR IN OPPOSITE DIRECTIONS

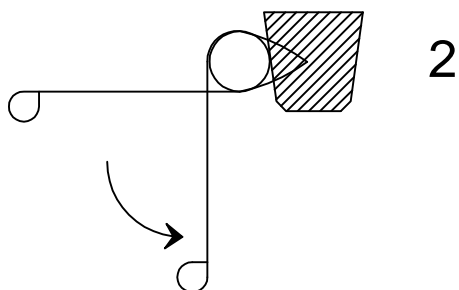

2

2 & 3: BEND WIRES AROUND EITHER SIDE OF REBAR IN OPPOSITE DIRECTIONS

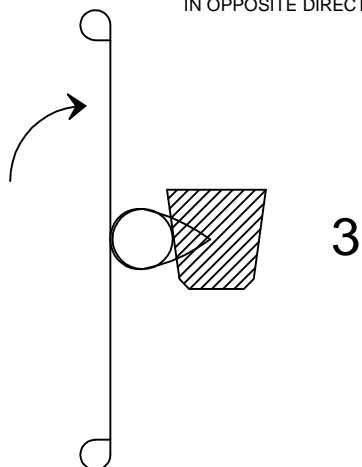

3

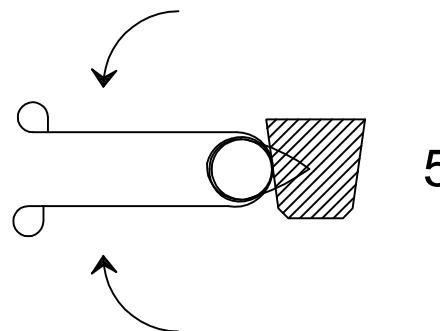

5

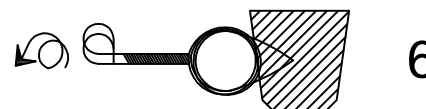

6

6: TWIST WIRES TOGETHER TIGHTLY TO COMPLETE THE CONNECTION, TAKE CARE NOT TO BREAK THE WIRES

**GALVASHIELD® N
EMBEDDED
GALVANIC ANODES**

**STEP BY STEP TIE WIRE
WRAP INSTALLATION
DETAIL**

BY: JWH DATE: Nov 20-2012

SHEET: 4 OF 4

N CONNECTION.DWG